

# 深圳市占開科技有限公司

ShenZhen ZhanKai Technology CO.,LTD

TEL:0769-81802125

FAX:0769-81802126

DOCUMENT NO.

RDE0012A

SERIAL NO.

A2001H

Material: Nylon 66 UL 94V-0 (White)

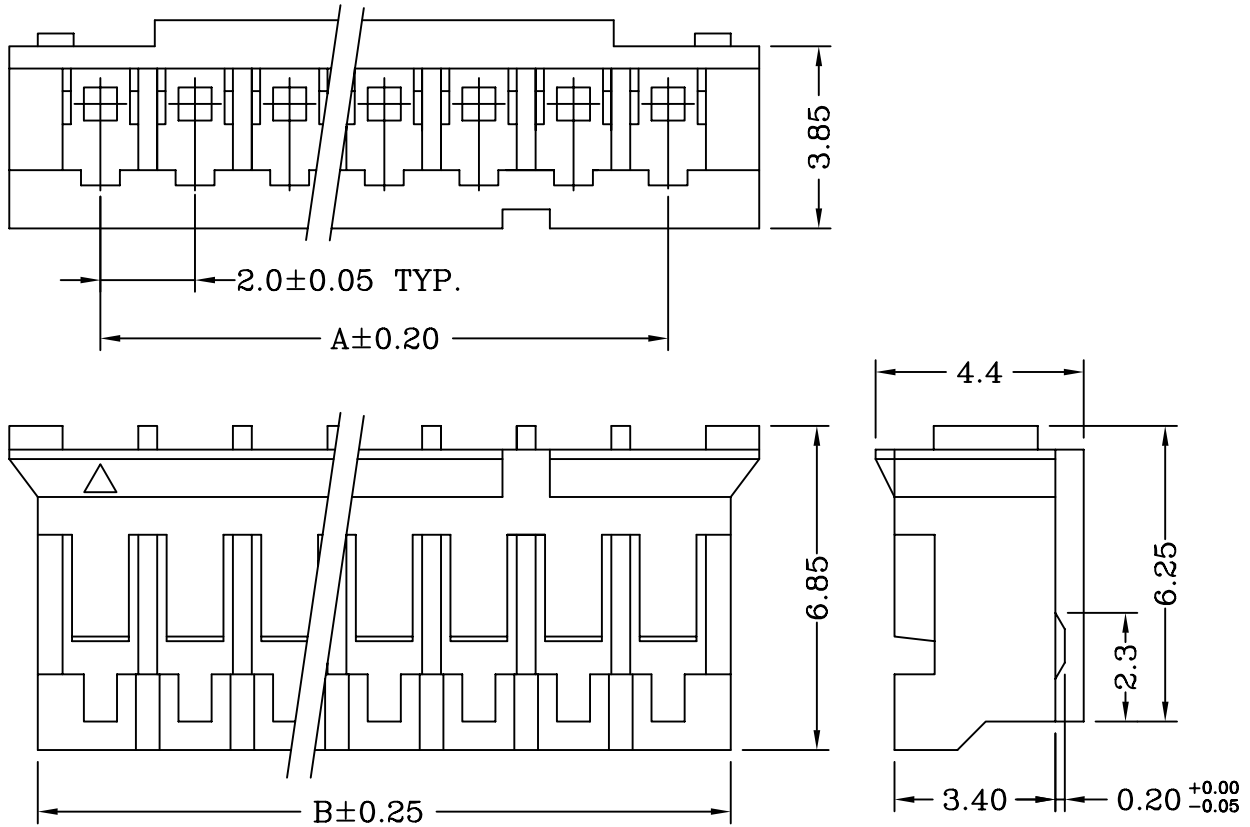

### Dimensional & Ordering Information:

Circuits	Part No	Dimensions		PCS/BAG
		A	B	
2	A2001H00-2P	2.00	4.50	1000
3	A2001H00-3P	4.00	6.50	1000
4	A2001H00-4P	6.00	8.50	1000
5	A2001H00-5P	8.00	10.50	1000
6	A2001H00-6P	10.00	12.50	1000
7	A2001H00-7P	12.00	14.50	1000
8	A2001H00-8P	14.00	16.50	1000
9	A2001H00-9P	16.00	18.50	1000
10	A2001H00-10P	18.00	20.50	1000
11	A2001H00-11P	20.00	22.50	1000
12	A2001H00-12P	22.00	24.50	1000
13	A2001H00-13P	24.00	26.50	1000
14	A2001H00-14P	26.00	28.50	1000
15	A2001H00-15P	28.00	30.50	1000
16	A2001H00-16P	30.00	32.50	1000
17	A2001H00-17P	32.00	34.50	1000
18	A2001H00-18P	34.00	36.50	1000
19	A2001H00-19P	36.00	38.50	1000
20	A2001H00-20P	38.00	40.50	1000

REV.	ECN NO.	UNIT	TOLERANCE	PROJECTION	DRAWING	CHECK	APPROVAL
△	NEW DRAWING	mm	*** ±0.08		王昊	—	余望明
△			** ±0.15				
△			* ±0.25				

# 深圳市占開科技有限公司

ShenZhen ZhanKai Technology CO.,LTD

TEL:0769-81802125

FAX:0769-81802126

DOCUMENT NO.

RDE0002A

SERIAL NO.

A2001T0\*-2

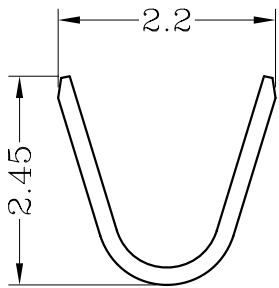
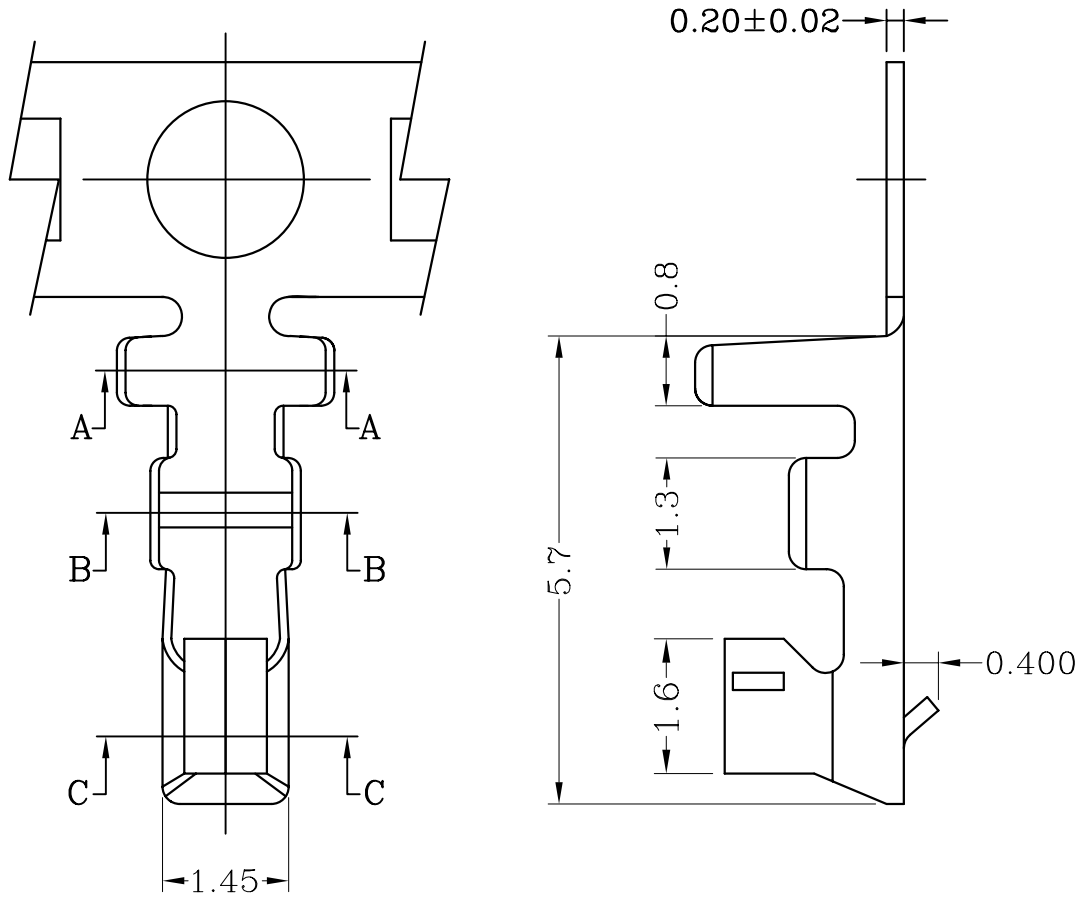

Section A-A

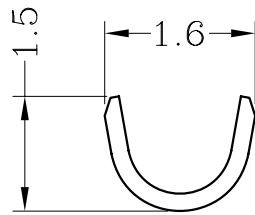

Section B-B

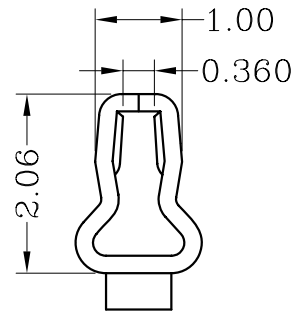

Section C-C

**Specifications & Ordering Information:**

Part No	Wire Range	Insulation O.D.	Material	Finish	Qty/reel
A2001TOP-2	AWG #24~#30	1.40mm(max)	Phosphor bronze	Tin-plated	12,000 PCS
A2001TOB-2	AWG #24~#30	1.40mm(max)	Brass	Tin-plated	12,000 PCS

REV.	ECN NO.	UNIT	TOLERANCE	PROJECTION	DRAWING	CHECK	APPROVAL
		mm	.*** ±0.08 .** ±0.15 * ±0.25		邹朝辉	—	余望明

# 深圳市占開科技有限公司

ShenZhen ZhanKai Technology CO.,LTD

TEL:0769-81802125

FAX:0769-81802126

DOCUMENT NO.

RDE0005A

SERIAL NO.

A2001WV0-NP

Material: \*Insulator: Nylon 66 UL 94V-0 (White)

\*Contact: Brass, Tin plating.

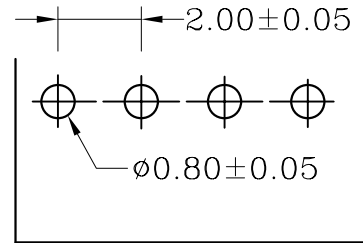
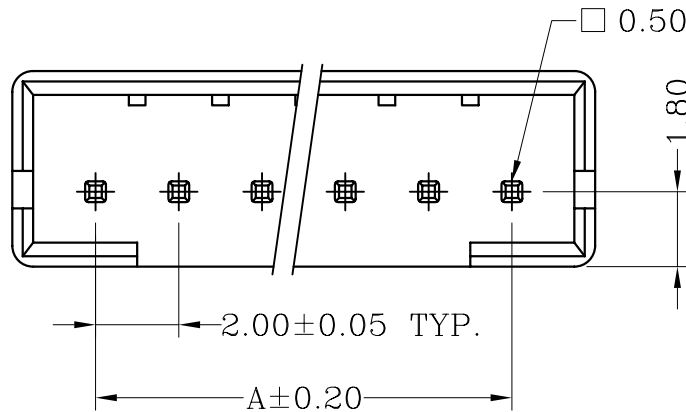

P.C.B LAYOUT

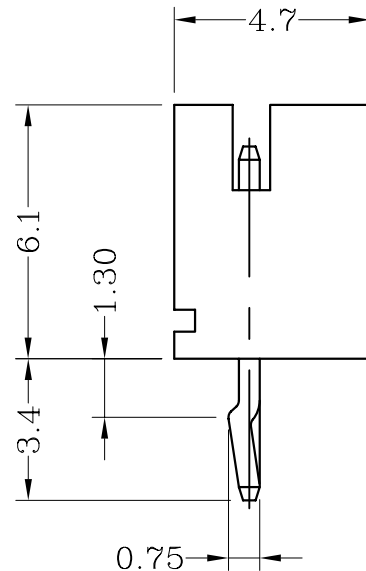
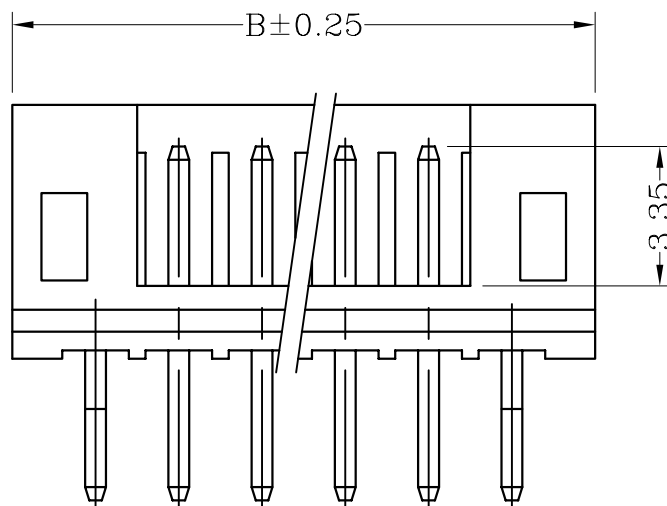

**Dimensional & Ordering Information:**

Circuits	Part No	Dimensions		PCS/BAG
		A	B	
2	A2001WV0-2P	—	6.00	1000
3	A2001WV0-3P	4.00	8.00	1000
4	A2001WV0-4P	6.00	10.00	1000
5	A2001WV0-5P	8.00	12.00	1000
6	A2001WV0-6P	10.00	14.00	1000
7	A2001WV0-7P	12.00	16.00	500
8	A2001WV0-8P	14.00	18.00	500
9	A2001WV0-9P	16.00	20.00	500
10	A2001WV0-10P	18.00	22.00	500
11	A2001WV0-11P	20.00	24.00	500
12	A2001WV0-12P	22.00	26.00	500
13	A2001WV0-13P	24.00	28.00	500
14	A2001WV0-14P	26.00	30.00	500
15	A2001WV0-15P	28.00	32.00	500
16	A2001WV0-16P	30.00	34.00	500

REV.	ECN NO.	UNIT	TOLERANCE	PROJECTION	DRAWING	CHECK	APPROVAL
A	NEW DRAWING	mm	.*** ±0.08		邹朝辉	——	余望明
B			.** ±0.15				
			.* ±0.25				

# 深圳市占開科技有限公司

ShenZhen ZhanKai Technology CO.,LTD

TEL:0769-81802125

FAX:0769-81802126

DOCUMENT NO.

RDE0006A

SERIAL NO.

A2001WR0-NP

Material: \*Insulator: Nylon 66 UL 94V-0 (White)

\*Contact: Brass, Tin plating.

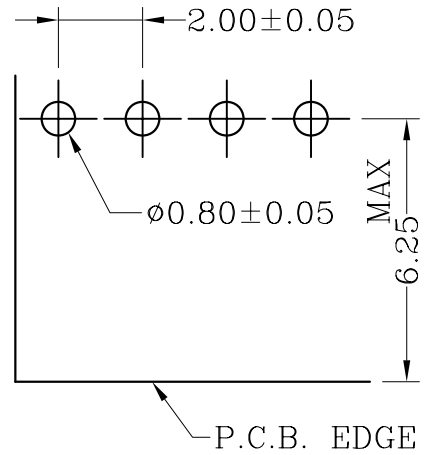
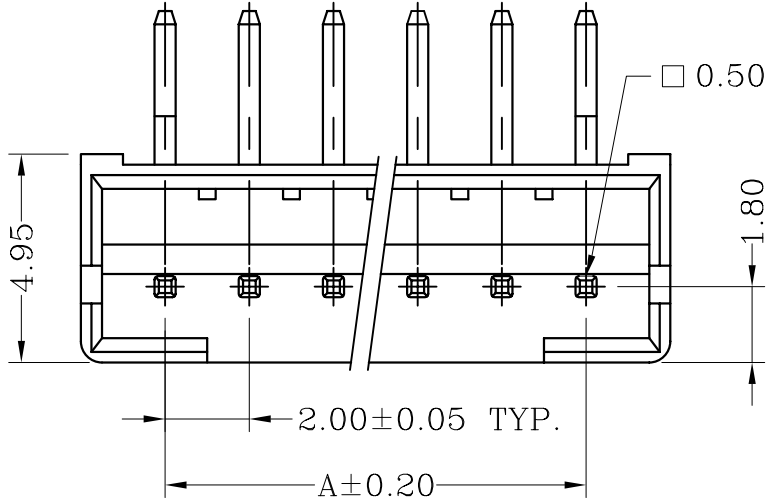

P.C.B LAYOUT

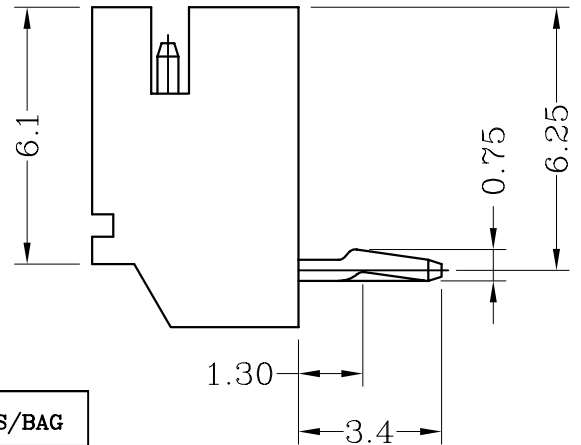
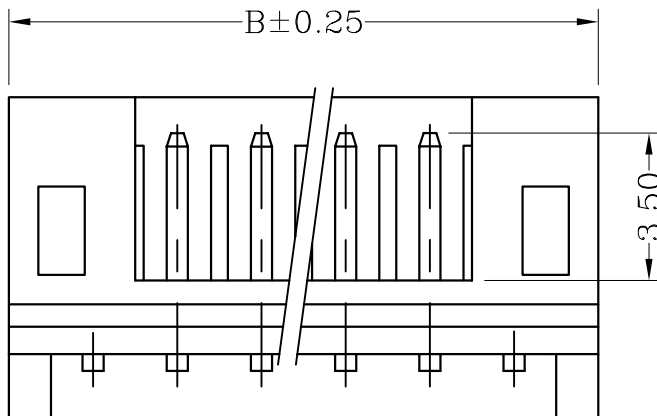

Dimensional & Ordering Information:

Circuits	Part No	Dimensions		PCS/BAG
		A	B	
2	A2001WR0-2P	—	6.00	1000
3	A2001WR0-3P	4.00	8.00	1000
4	A2001WR0-4P	6.00	10.00	1000
5	A2001WR0-5P	8.00	12.00	1000
6	A2001WR0-6P	10.00	14.00	1000
7	A2001WR0-7P	12.00	16.00	500
8	A2001WR0-8P	14.00	18.00	500
9	A2001WR0-9P	16.00	20.00	500
10	A2001WR0-10P	18.00	22.00	500
11	A2001WR0-11P	20.00	24.00	500
12	A2001WR0-12P	22.00	26.00	500
13	A2001WR0-13P	24.00	28.00	500
14	A2001WR0-14P	26.00	30.00	500
15	A2001WR0-15P	28.00	32.00	500
16	A2001WR0-16P	30.00	34.00	500

REV.	ECN NO.	UNIT	TOLERANCE	PROJECTION	DRAWING	CHECK	APPROVAL
△	NEW DRAWING	mm	*** ±0.08		邹朝辉	—	余望明
△			** ±0.15				
△			* ±0.25				